

Replaces:  
RN 1936:2023-07-10

## Labelling

### Raw material, parts and gearboxes

Content	Page
1 Scope .....	2
2 References .....	2
3 Terms and Definitions.....	2
4 Raw materials, raw parts and samples.....	2
4.1 Manufacturer.....	2
4.2 Goods acceptance .....	2
5 Production and supplied parts .....	3
5.1 Embossing machines .....	3
5.2 Parts subject to labelling requirements .....	3
5.3 Standard positions for labelling.....	5
5.4 Housings .....	7
6 Gearboxes.....	9
6.1 Identification labels .....	9
6.2 Other labels .....	10

### Changes

2024-04-15:

The following changed in comparison to RN 1936:2023-07-10:

- a) Chapter 5.2: Specifications for the stamping of coupling carriers added
- b) Chapter 5.3: Figure 21 supplemented to show the coupling carrier

Responsible division: EK	Editor M. Förste	Approval: see doc. workflow	Technical reference: C. Eschert	Page: 1 / 10
-----------------------------	---------------------	--------------------------------	------------------------------------	-----------------

## 1 Scope

This Factory Standard applies to raw material resp. raw parts, torque-transmitting parts and gearboxes. It should secure a clear and lasting identification of parts and products subject to labelling.

## 2 References

The following documents, cited in part or in whole, shall apply for the use of this standard. In the case of dated references, only the referenced edition applies; in the case of undated references, the latest edition of the referenced document (including all amendments) applies. The applicable version of the standards listed below shall apply to all contents not covered by this factory standard.

RL-QS-002	Labelling of parts
RN 860-3	Delivery conditions for Castings; Aluminium alloys

## 3 Terms and Definitions

**Nameplate** (or rating plate) a by the manufacturer (or the responsible importer) mounted labelling of an object with identifying, descriptive and classifying data. Among other things, it is intended to ensure the legally compliant, unambiguous and permanent identification of an object (here a gearbox).

## 4 Raw materials, raw parts and samples

### 4.1 Manufacturer

Clear and lasting marking by hard stamping or labelling

- manufacturer’s mark (e.g. forging plant or foundry)
- material number or material designation with heat treatment condition
- batch or heat number
- REINTJES material number (blank parts, raw material)
- acceptance stamp (if applicable)

### 4.2 Goods acceptance

The goods receiving department marks the delivery note with the date of receipt as well as the corresponding sample number. Rolled and forged round steels as well as forgings are colour-coded.

**Table 1 Colour-coding of raw material**

material number	short name	colour 1		colour 2	
1.6587	18CrNiMo7-6	RAL 3000	flame red	RAL 6011	reseda green
1.7131	16MnCr5	RAL 3000	flame red	RAL 7031	blue grey
1.7220	34CrMo4	RAL 5009	azure blue	RAL 7031	blue grey
1.7225	42CrMo4	RAL 1004	golden yellow	--	--
1.8519	31CrMoV9	RAL 5009	azure blue	RAL 8003	clay brown
1.0037	S235JR	RAL 3000	flame red	--	--
1.0050	E295	RAL 1013	oyster white	RAL 6011	reseda green
1.0570	S355J2G3	RAL 8003	clay brown	RAL 6011	reseda green

1.0060	E335	RAL 6011	reseda green	RAL 6011	reseda green
1.6582	34CrNiMo6	RAL 3000	flame red	RAL 1013	oyster white

## 5 Production and supplied parts

### 5.1 Embossing machines

Preferably, embossing machines should be chosen for the marking on the finished component. It should be noted that the embossing force is selected in such a way that

- the notch effect caused by the embossing is as low as possible
- the legibility of the marking must also be given after heat treatment

If marking with embossing equipment is not possible, impact stamps can be used.

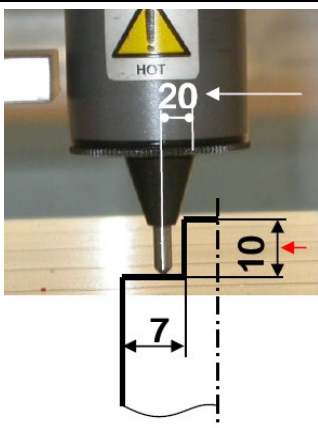
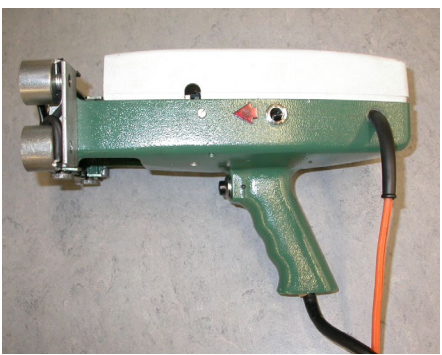
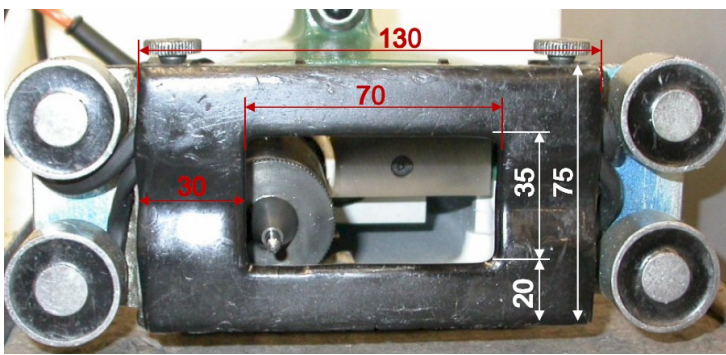
<p><math>m \leq 50 \text{ kg}, d_{\text{max}} \leq 245 \text{ mm}</math></p>	 <p>figure 1 WOSTOR 150</p>	 <p>figure 2 Limits</p> <p>to be considered, if projection length &gt; 10 mm</p> <p>in special occasions allowed up to max. 50 mm</p>
<p><math>m &gt; 50 \text{ kg}, d_{\text{max}} &gt; 245 \text{ mm}</math></p>	 <p>figure 3 WOSTOR hand embosser</p>	 <p>figure 4 dimensions hand embosser</p>

**Note:** The smallest digit size to be realised is 5 mm, i.e.  
 -> wave heels for inscription should be at least 7 mm wide  
 -> wave heel jumps should be a maximum of 10 mm

### 5.2 Parts subject to labelling requirements

Components that are in the power flow and transmit torque must be marked with various labels (see below) from the start of production for identification and documentation purposes. The determination of whether a component is subject to marking, results from the marking as a component that is subject to an acceptance requirement or receives an acceptance certificate or a type approval. This information is found in the SAP master data of the material.

Example:

**Material**

Material: A520748

Bezeich: Kupp. Gehäuse Stg. L mn 5,0 Z 45

Benenn. 2: [ ]

Benenn. 3: [ ]

---

**Zusatzdaten**

Baureihe: WVS

Baugröße: 430

Bauform: [ ]

Teilecode: 4-278-00000

NATO-Nummer: [ ]

Vorlagematerial: V\_HALB\_1

Führende Zeichnung: 4-278-44246

Abnahmepflicht

Abnahmezeugnis

Abnahmetypgenehmigung

figure 5 Acceptance requirements in the SAP master data for the material (Transaction MM03 in SAP -> *Fundamental Data 1*)

The labelling of finished goods has to be lasting and perfectly legible. For In-house production parts, usually embossing machines or impact stamps are used. The specifications for internally marking are in RL-QS-002.

The labelling contains following data:

**Samples:**

- sample no.

**Pre-turned parts:**

- production order no. (FAUF)
- drawing no.
- sample no.

**Finished parts:**

- production order no. (FAUF) incl. index no.
- drawing no.
- personalised stamp
- sample no.
- acceptance plate (if applicable)
- raw material no. (for coupling carrier)

Each number can be found in the production documents.

E.g. for parts subject to labelling (without claim to completeness):

- |  |   |
|--|---|
| <ul style="list-style-type: none"> <li>• housing</li> <li>• pinion shaft</li> <li>• pinion carrier and pinion, if built</li> <li>• large wheel</li> <li>• coupling housing, gearing</li> <li>• brake housing</li> <li>• coupling carrier</li> <li>• carrier</li> </ul> | <ul style="list-style-type: none"> <li>• drive shaft</li> <li>• intermediate shaft</li> <li>• output shaft</li> <li>• auxiliary drive shaft (e.g. PTO)</li> <li>• gearing auxiliary drive (e.g. PTO)</li> <li>• counter flange propeller side</li> <li>• flange motor side</li> <li>• track disc</li> </ul> |
|--|---|

**IMPORTANT:** If the marking is completely or partially removed or becomes illegible in the manufacturing process, it shall be renewed as far as possible immediately after the operation, but after completion of the component at the latest.

Additionally following purchased parts are subject to labelling, e.g.:

- heat exchanger
- compensators
- double change-over filter
- flanged pump
- pump unit
- flexible coupling
- fitting bolts
- slide bearings

Examples for parts **not** to be hard stamped:

- covers
- brackets
- discs, bushes, rings
- drillings on output shafts (labelling preferred with etching pen s. Fig. 8 und 9)

### 5.3 Standard positions for labelling

The labelling should be applied in compliance with the above limits for embossing machines as to

- remain unambiguously legible even after the last edit,
- lie under no circumstances on functional surfaces (seats, fits, etc.),
- be as far as possible not in the power flow or in a torque-transmitting area and
- can be seen from the outside with shafts protruding from the gearbox.

In the case of flanges and flanged shafts (except drive shafts), labelling must normally be made on the outer flange diameter, in the case of smooth shafts on an end face or, if there is insufficient space, on the circumference. If a positioning deviating from this is required for technical reasons, this must be noted in the production documents (preferably drawings).

Unless otherwise specified in the manufacturing documents, following standard positions apply:

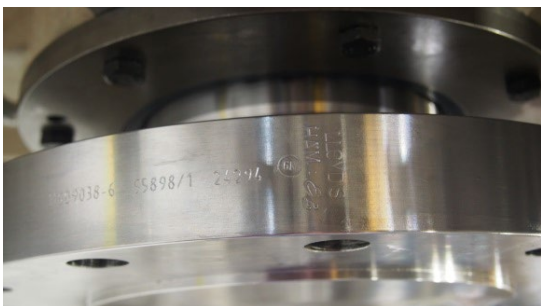

figure 6 flanges, output shafts, intermediate shafts with flange: on outer flange diameter



figure 7 drive shafts, output shafts without flange: on the outer end face  
intermediate shaft without flange: end face



figure 8 output shaft: labelling with etching pen for two drilling holes



figure 9 output shaft: labelling with etching pen for three drilling holes



figure 10 carrier: end face



figure 11 coupling carrier: end face  
if necessary: end face of the gearing



figure 12 gear, pinion: wheel body



figure 13 pinion shaft: behind the run-out  
of the driving gearing



figure 14 shaft pump unit: circumference



figure 15 pump wheel: wheel body

Examples of labelling for purchased parts:



figure 16 slide bearings



figure 17 pump (hard stamping)



figure 18 flexible coupling



figure 19 coupling

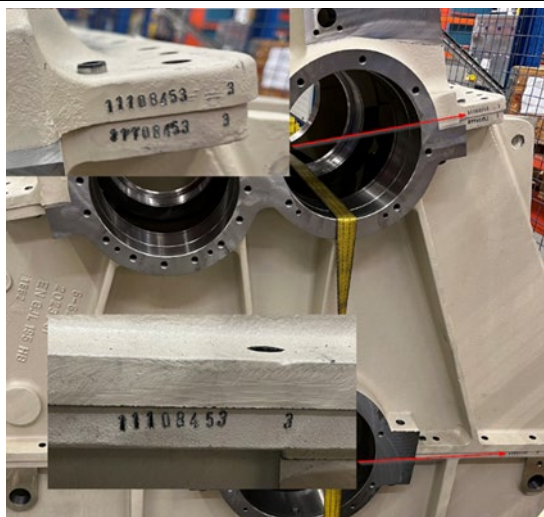

figure 20 Housing



figure 21 coupling carrier

### 5.4 Housings

All housing parts, bearing brackets and covers must be marked clearly, visibly and legibly using a stamping or punching procedure (e.g. marking punch) with a character height of 6 mm minimum.

All housing parts must be marked on the unmachined outside surface of the joint (see figures 20 and 21) in mounted condition. Covers and bearing brackets must be marked in a way that they can easily be assigned to the different parts of the gearbox.

Based on order data, the housing components generally must be marked according to the following table:

**Table 2 Labelling**

	commission no.	manuf. ident no.	consecutive no.	example
steel housing or steel/cast housing	X			K71000
cast housing		X	X	C00954-1
bearing bracket			X	1
cover			X	2

acc. to order marked  
with commission no. or  
manuf. ident. no., e.g.:  
**K75324** or  
**C00954 -1**

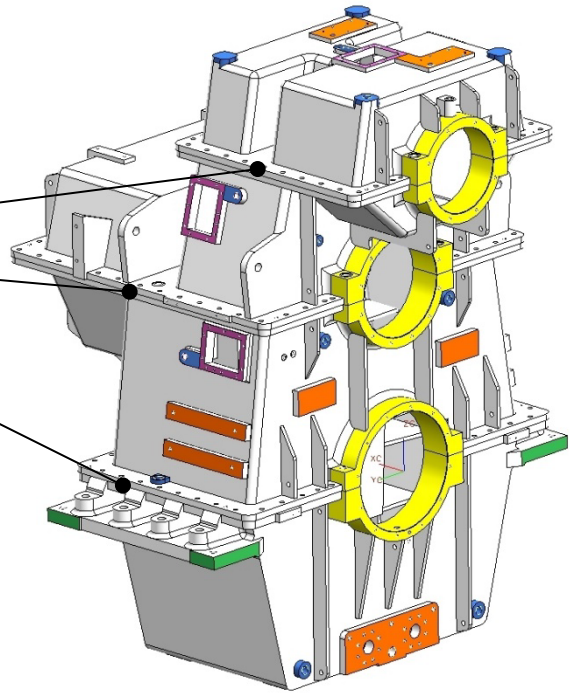

figure 22

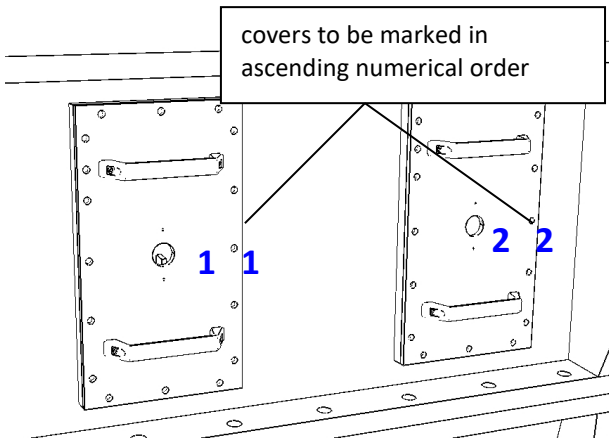

figure 23

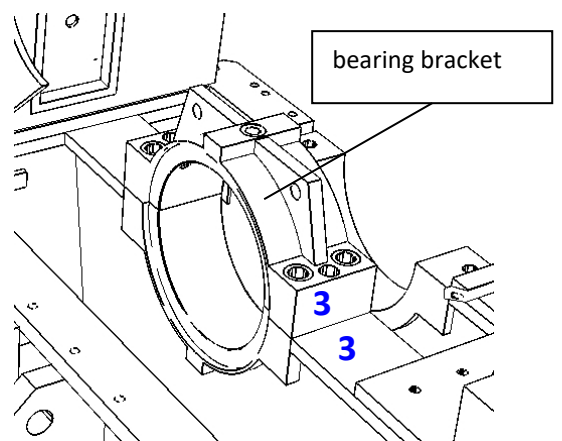

figure 24



## 5.5 Castings

<b>Part categories</b>
A) gearbox- or intermediate housings with classification acc. to hardness values
B) Bushes and other small parts with classification acc. to tensile strength
C) Bearing housings, coupling carriers etc. with classification acc. to tensile strength

The part categories B and C differ acc. to the delivery specification with regard to the material. If category C is not available there, all components except enclosures are classified acc. to category B.

Labelling with	part category		
	A <sup>4)</sup>	B	C
Manufacturer's mark	X	X	X
Model No. REINTJES	X	X	X
Part No. REINTJES (If different from Model No.)	X	X	X
Melt-No. and casting date	X	(X) <sup>1)</sup>	X
Material designation	X		

<sup>1)</sup> applies for parts acc. to RN 860-3

For permanent preservation of the labelling of the parts, it should be applied in an area that will not be mechanically processed later. As a rule, suitable areas are marked in the blank drawing. REINTJES should be consulted if this information is missing.

## 6 Gearboxes

### 6.1 Identification labels

Acc. machinery directive, annex I 1.7.3, following data has to be recognisable, clearly legible and permanently affixed to machines in the minimum:

- company name and complete address of the manufacturer and, if applicable, its representative
- designation of the machine
- CE Mark
- series or type designation and if applicable serial number
- year of manufacture resp. year, in which the manufacturing process was completed

The CE mark may only be affixed to products subject to marking. The CE marking is generally not required for partly completed machinery (gearboxes), for marine propulsion systems and other products that do not fall within the scope of the relevant EU regulations or directives (e.g. the Machinery Directive EC 2006/42).

For REINTJES gearboxes, further characteristic features indicated on the nameplate are:

- reduction ratio
- input direction of drive rotation
- weight
- output direction of drive rotation

- input speed
- drive power
- oil change amount
- output speed
- max. power torque (P/n)
- oil viscosity

REINTJES nameplates

- are designed as metal plates and riveted to the gearbox so that they are always readable
- are available in different languages (see order)
- receive the acceptance stamp for gearboxes with acceptance requirement

In addition, a nameplate is attached to the gearbox for each function of an auxiliary drive (preferably near the shaft journal), i.e. auxiliary drives with dual functions (e.g. K55, PTO/PTI) receive two nameplates.

Characteristics to be indicated for auxiliary drives:

- serial no. (gearbox)
- function
- reduction ratio
- performance
- type (auxiliary drive)
- sense of rotation
- rotational speed
- max. power torque (P/n)

Examples:

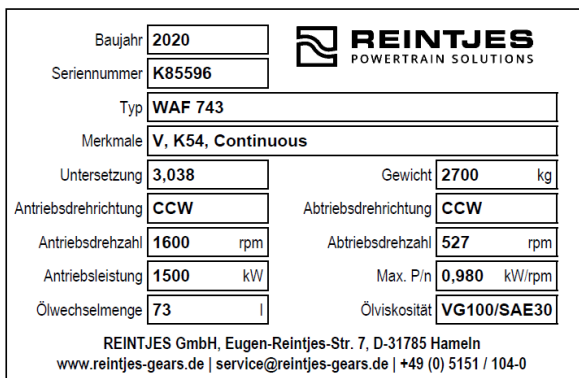

figure 25 nameplate gearbox

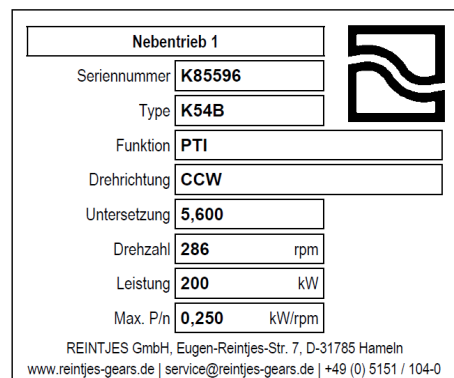

figure 26 nameplate auxiliary drive

6.2 Other labels

Depending on the design, further information, warning or instruction signs are attached to the gear unit or suitable components, e.g.:

- arrows for direction of rotation (attachment near outer shaft ends)
- label "work safety" (warning notice for the disassembly of couplings and flanges)
- label "anchor point" (notice on all anchor points)
- label "Branorol" (reference to VCI preservative oil contained in the delivery condition)
- label "storage of gearbox" (reference to corrosion protection measures)
- label "Fill in oil" (note on oil filler hole on gearbox)
- label "grounding sign"
- further identification plates from surveillance, etc.